



A GROUP SYNERGY



A GROUP SYNERGY



CABLE CONTAINMENT MANUFACTURERS



EXPERT OFFSITE MANUFACTURING



CORROSIVE & HAZARDOUS ENVIRONMENTS

With three specialist divisions, Hudson Group offers one of the most comprehensive cable management propositions in the industry. Our experience and expertise across manufacturing, prefabrication, design, modularisation and materials, means we're able to provide cable support solutions for every project, in any environment.



As a high volume UK manufacturer of standard and custom cable management solutions, Armorduct's success has been founded on flexibility and customer service.



RMS are experts in cable containment solutions for the most demanding installations, specialising in offsite manufacturing for prefabricated, modular and fast-install systems.



Experienced technical consultants for cable management projects, specialising in solutions for corrosive and hazardous environments.



CABLE CONTAINMENT MANUFACTURERS

Founded in 1998, Armorduct are a high volume UK manufacturer of cable management components and systems.

Combining our extensive portfolio of standard products with our in-house design capability enables us to provide the right product and the right solution every time.



Based in the Midlands, we supply cable trunking, cable tray and cable basket, plus lighting, flooring and perimeter cable containment solutions for UK and European projects.

We provide specialist solutions for the rail industry that are Network Rail & TfL approved.

Working closely with our customers is the best way to ensure the most successful outcomes, all supported through our partner network of electrical distributors.

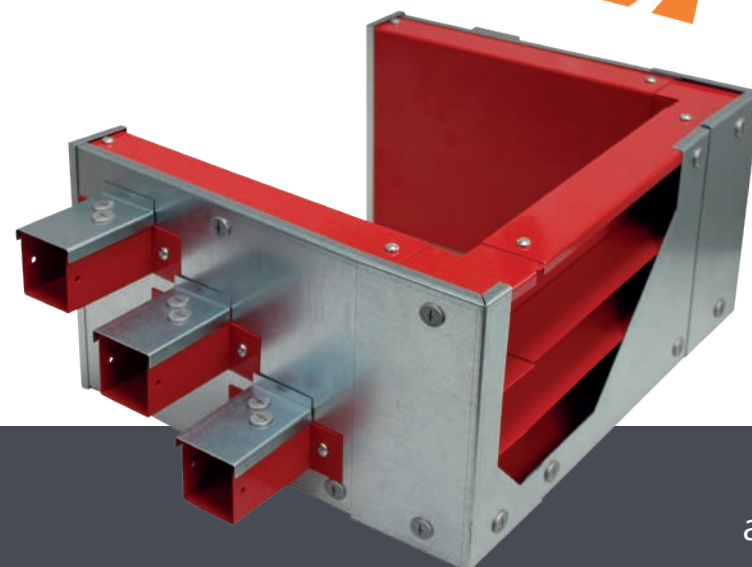
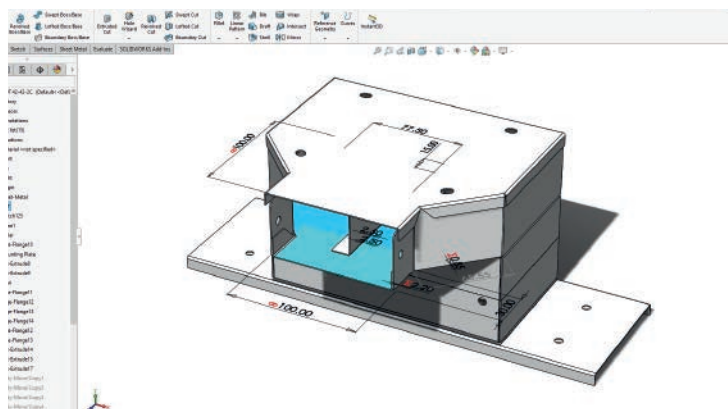
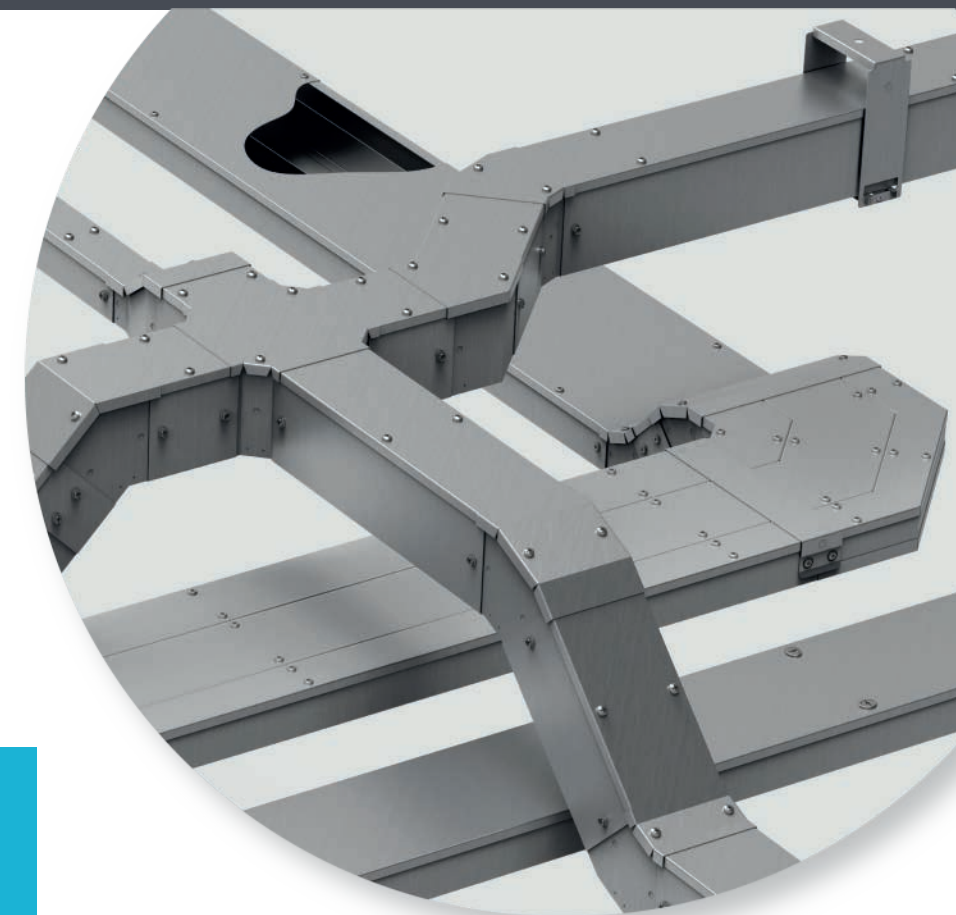

ISO 9001 Certified
ISO 14001 Certified



EXPERT OFFSITE MANUFACTURING

Delivering projects for fixed budgets on fixed timescales and in more sustainable ways, means offsite fabrication services are now becoming mission critical for our customers.

Our prefabricated brackets, frames, containment modules and systems are delivered direct to site ready for rapid install, using minimal labour and with minimal waste materials.

Established in 1993, RMS has supported some of the largest construction projects across the UK and Europe.

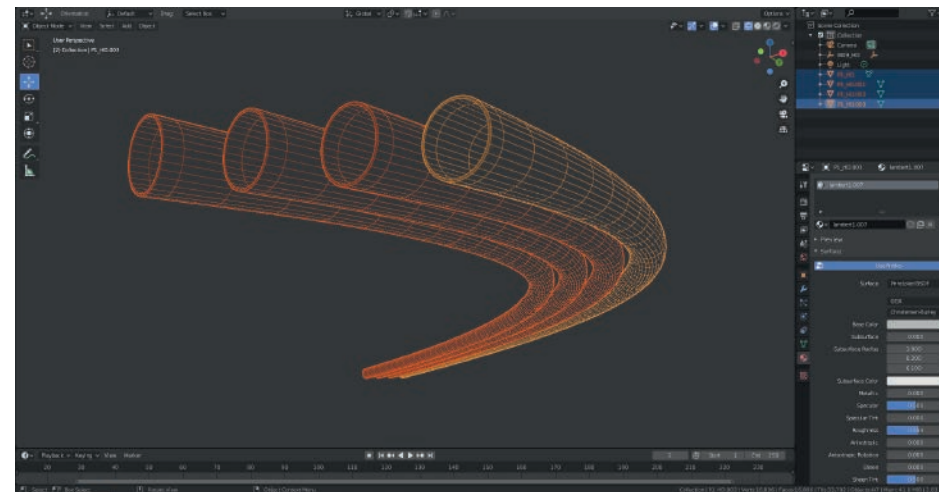

DESIGN *for*
MANUFACTURE
& **ASSEMBLY**

Where projects present unique challenges in terms of navigating cables into and around a building, we provide robust cable management solutions to ensure that a system is easy to install, maintain and develop moving forward. Data centres are a great example of where we've developed fast-install containment modules.

We become trusted advisors to deliver project certainty:

- Labour Certainty
- Time Certainty
- Cost Certainty
- Factory Quality Certainty
- Carbon Certainty 



CORROSIVE & HAZARDOUS ENVIRONMENTS

Milton provide solutions for harsh and extremely corrosive environments. We specialise in "fit and forget" cable management systems for electrical and mechanical installations where durability, reliability and quality are critical for the lifetime of the project.



Selecting the correct materials to perform in challenging conditions is critical, and we provide industrial expertise across GRP, stainless steel and zinc-magnesium alloy technologies.

We're delighted to partner with the Wibe Group to bring you the industry's premier GRP cable support products from Mita.



Transport

- Railways
- Tunnels
- Airports
- Ports
- Bridges



Water

- Desalination
- Waste Water
- Utilities
- Pools
- Marine



Plants

- Chemical
- Pharma
- Food & Beverage
- Data Centres
- ATEX Areas



Power & Grid

- Wind
- BioMass
- Solar
- Nuclear
- Oil & Gas

Milton also provide a consultancy and CPD-approved training service across the Hudson Group, harnessing the combined products and services of our divisions, offering decades of experience and technical expertise in cable management.



A GROUP SYNERGY

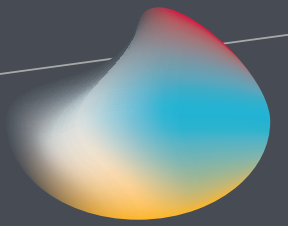

COMPONENTS

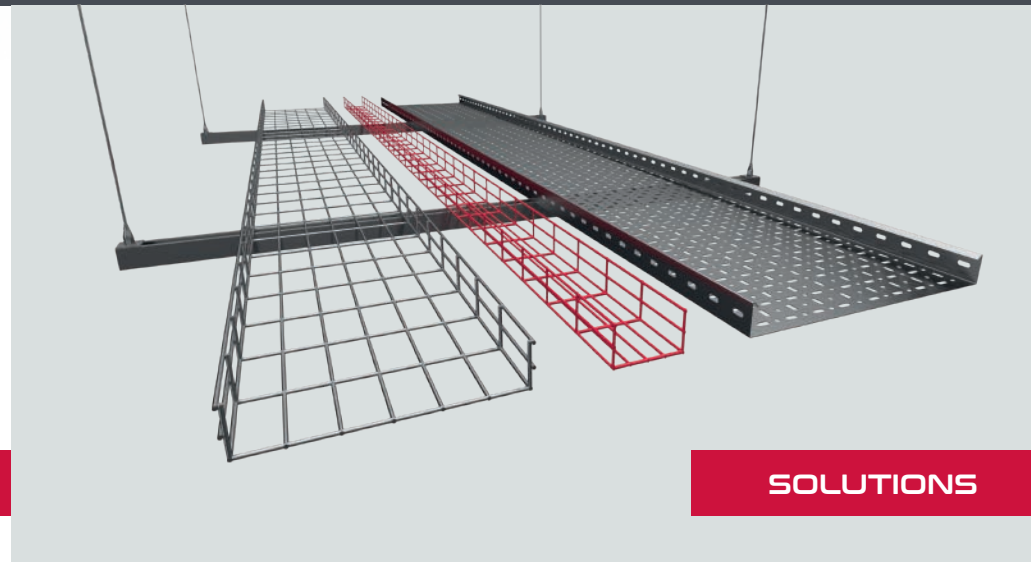

SOLUTIONS

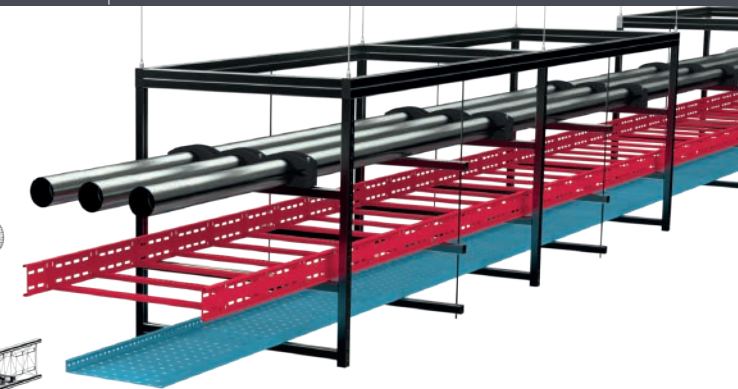
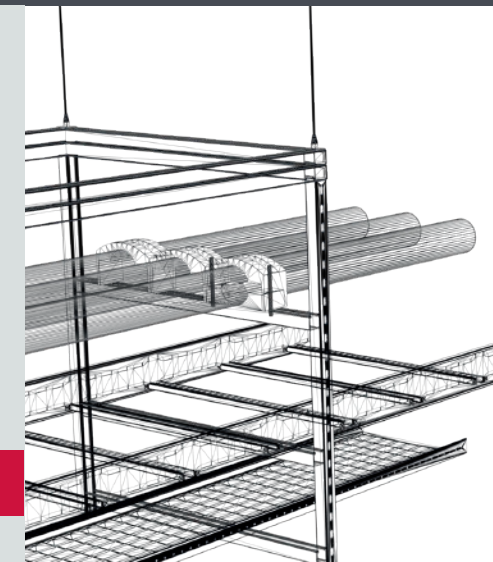

MODULES

IN-HOUSE ENGINEERING

Real-world electrical installations frequently require fast, innovative solutions. Direct links with our engineering teams allow problems to be understood quickly, opening up access to the design, manufacturing and fabrication capabilities within our Group.

From minor standard product modifications to fully **value-engineered** modular systems, our in-house developers offer the experience and flexibility to support the most challenging of projects.

